

Rev	Date	Modified by	Description
A0	2023		

Product Specifications

10Gbps CWDM 10KM SFP+ Transceiver

PN: ESCxxX-10D

Features

- Up to 11.3Gbps Data Links
- Up to 10km transmission on SMF
- Power dissipation <1.5W
- Uncooled CWDM DFB Laser and PIN receiver
- Metal enclosure, for lower EMI
- 2-wire interface with integrated Digital Diagnostic monitoring
- Hot-pluggable SFP+ footprint
- Specifications compliant with SFF 8472
- Compliant with SFP+ MSA with LC connector
- Single 3.3V power supply
- Case operating temperature range:0°C to 70°C

Applications & Standards

- 10GBASE-LR/LW
- 10G Ethernet
- Compliant to 802.3ae 10GBASE-LR/LW
- Compliant to SFF-8431
- RoHS Compliant.

Product Selection

Wavelength	xx	Clasp Color Code	Wavelength	xx	Clasp Color Code
1271 nm	27	Gray	1371 nm	37	Green
1291 nm	29	Gray	1391 nm	39	Yellow
1311 nm	31	Gray	1411 nm	41	Orange
1331 nm	33	Purple	1431 nm	43	Red
1351 nm	35	Blue	1451 nm	45	Brown

Absolute Maximum Ratings

Parameter	Symbol	Min.	Typ.	Max.	Unit	Note
Storage Temperature	Ts	-40	-	85	°C	
Relative Humidity	RH	5	-	95	%	
Power Supply Voltage	VCC	-0.3	-	4	V	
Signal Input Voltage		Vcc-0.3	-	Vcc+0.3	V	

Recommended Operating Conditions

Parameter	Symbol	Min.	Typ.	Max.	Unit	Note
Case Operating Temperature	Tcase	0	-	70	°C	Without air flow
Power Supply Voltage	VCC	3.14	3.3	3.47	V	
Power Supply Current	ICC	-		450	mA	
Data Rate	BR		10.3125		Gbps	
Transmission Distance	TD		-	10	km	
Coupled fiber	Single mode fiber					9/125um SMF

Recommended Operating Conditions

Parameter	Symbol	Min	Typ	Max	Unit	NOTE
Transmitter						
Output Opt. Power	POUT	-6		-0.5	dBm	1
Optical Wavelength	λ	$\lambda-6.5$		$\lambda+6.5$	nm	2
Spectral Width (-20dB)	σ			1	nm	
Optical Extinction Ratio	ER	3.5			dB	
Transmitter and Dispersion Penalty	TDP			3.2	dB	
Side mode Suppression ratio	SMSR	30			dB	
Output Eye Mask			Compliant with IEEE 802.3ae			
Receiver						
Receiver Sensitivity	Psen			-15	dBm	3
Input Saturation Power (Overload)	PSAT	1.5			dBm	
Input Optical Wavelength	λ_{IN}	1270		1610	nm	
LOS -Assert Power	PA	-30			dBm	
LOS -Deassert Power	PD			-18	dBm	
LOS -Hysteresis	Phys	0.5			dB	

Notes:

- 1、Class 1 Laser Safety per FDA/CDRH and IEC-825-1 regulations.
- 2、" λ " is: 1271, 1291, 1311, 1331, 1351, 1371, 1391, 1411, 1431, 1451 please the "product selection".
- 3、Measured with a PRBS $2^{31}-1$ test pattern, @10.325Gb/s, BER < 10^{-12}

Electrical Characteristics

Parameter	Symbol	Min	Typ	Max	Unit	NOTE
Supply Voltage	Vcc	3.14	3.3	3.46	V	
Supply Current	Icc			450	mA	
Transmitter						
Input differential impedance	Rin		100		Ω	1
Differential data input swing	Vin,pp	180		1200	mV	

Transmit Disable Voltage	VD	Vcc-1.3		Vcc	V	
Transmit Enable Voltage	VEN	Vee		Vee+ 0.8	V	2
Transmit Disable Assert Time				10	us	
Receiver						
Differential data output swing	Vout,pp	300		850	mV	3
Data output rise time	tr	30			ps	4
Data output fall time	tf	30			ps	4
LOS Fault	VLOS fault	Vcc-1.3		VccHOST	V	5
LOS Normal	VLOS norm	Vee		Vee+0.8	V	5
Power Supply Rejection	PSR	100			mVpp	6

Notes:

1. Connected directly to TX data input pins. AC coupled thereafter.
2. Or open circuit.
3. Input 100 ohms differential termination.
4. These are unfiltered 20-80% values
5. Loss Of Signal is LVTTTL. Logic 0 indicates normal operation; logic 1 indicates no signal detected.
6. Receiver sensitivity is compliant with power supply sinusoidal modulation of 20 Hz to 1.5 MHz up to specified value applied through the recommended power supply filtering network.

Pin Descriptions

Pin	Symbol	Name/Description	NOTE
1	V _{EET}	Transmitter Ground (Common with Receiver Ground)	1
2	T _{FAULT}	Transmitter Fault.	2
3	T _{DIS}	Transmitter Disable. Laser output disabled on high or open.	3
4	SDA	2-wire Serial Interface Data Line	4
5	SCL	2-wire Serial Interface Clock Line	4
6	MOD_ABS	Module Absent. Grounded within the module	4
7	RS0	Rate Select 0	5
8	LOS	Loss of Signal indication. Logic 0 indicates normal operation.	6
9	RS1	No connection required	1
10	V _{EER}	Receiver Ground (Common with Transmitter Ground)	1

11	V _{EER}	Receiver Ground (Common with Transmitter Ground)	1
12	RD-	Receiver Inverted DATA out. AC Coupled	
13	RD+	Receiver Non-inverted DATA out. AC Coupled	
14	V _{EER}	Receiver Ground (Common with Transmitter Ground)	1
15	V _{CCR}	Receiver Power Supply	
16	V _{CCT}	Transmitter Power Supply	
17	V _{EET}	Transmitter Ground (Common with Receiver Ground)	1
18	TD+	Transmitter Non-Inverted DATA in. AC Coupled.	
19	TD-	Transmitter Inverted DATA in. AC Coupled.	
20	V _{EET}	Transmitter Ground (Common with Receiver Ground)	1

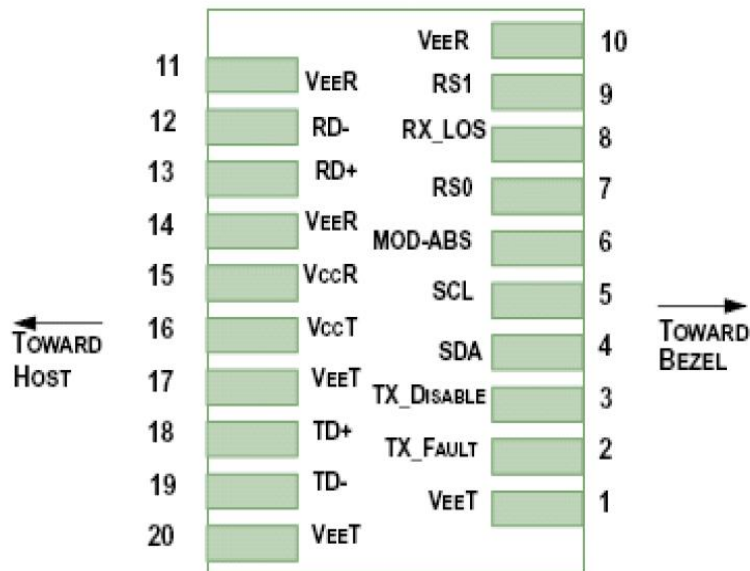

Diagram of Host Board Connector Block Pin Numbers and Name

Notes:

- 1、Circuit ground is internally isolated from chassis ground.
- 2、TFAULT is an open collector/drain output, which should be pulled up with a 4.7k – 10k Ohms resistor on the host board if intended for use. Pull up voltage should be between 2.0V to Vcc + 0.3V. A high output indicates a transmitter fault caused by either the TX bias current or the TX output power exceeding the preset alarm thresholds. A low output indicates normal operation. In the low state, the output is pulled to <0.8V.
- 3、Laser output disabled on T_{DIS}>2.0V or open, enabled on T_{DIS}<0.8V.
- 4、Should be pulled up with 4.7kΩ- 10kΩ host board to a voltage between 2.0V and 3.6V. MOD_ABS pulls line low to indicate module is plugged in.
- 5、Internally pulled down per SFF-8431 Rev 4.1.
- 6、LOS is open collector output. It should be pulled up with 4.7kΩ – 10kΩ on host board to a voltage between 2.0V and 3.6V. Logic 0 indicates normal operation; logic 1 indicates loss of signal.

Digital Diagnostic Functions

ETU-Link's ESCxxX-3LCD10 transceivers support the 2-wire serial communication protocol as defined in the SFP+MSA.

The standard SFP serial ID provides access to identification information that describes the transceiver's capabilities, standard interfaces, manufacturer, and other information.

Additionally, ETU-Link's SFP+ transceivers provide a unique enhanced digital diagnostic monitoring interface, which allows real-time access to device operating parameters such as transceiver temperature, laser bias current, transmitted optical power, and received optical power and transceiver supply voltage. It also defines a sophisticated system of alarm and warning flags, which alerts end-users when particular operating parameters are outside of a factory set normal range.

The SFP+ MSA defines a 256-byte memory map in EEPROM that is accessible over a 2-wire serial interface at the 8 bit address 1010000X (A0h). The digital diagnostic monitoring interface makes use of the 8 bit address 1010001X (A2h), so the originally defined serial ID memory map remains unchanged.

The operating and diagnostics information is monitored and reported by a Digital Diagnostics Transceiver Controller (DDTC) inside the transceiver, which is accessed through a 2-wire serial interface. When the serial protocol is activated, the serial clock signal (SCL, Mod Def 1) is generated by the host. The positive edge clocks data into the SFP transceiver into those segments of the EEPROM that are not write-protected. The negative edge clocks data from the SFP transceiver. The serial data signal (SDA, Mod Def 2) is bi-directional for serial data transfer. The host uses SDA in conjunction with SCL to mark the start and end of serial protocol activation. The memories are organized as a series of 8-bit data words that can be addressed individually or sequentially.

Host - Transceiver Interface Block Diagram

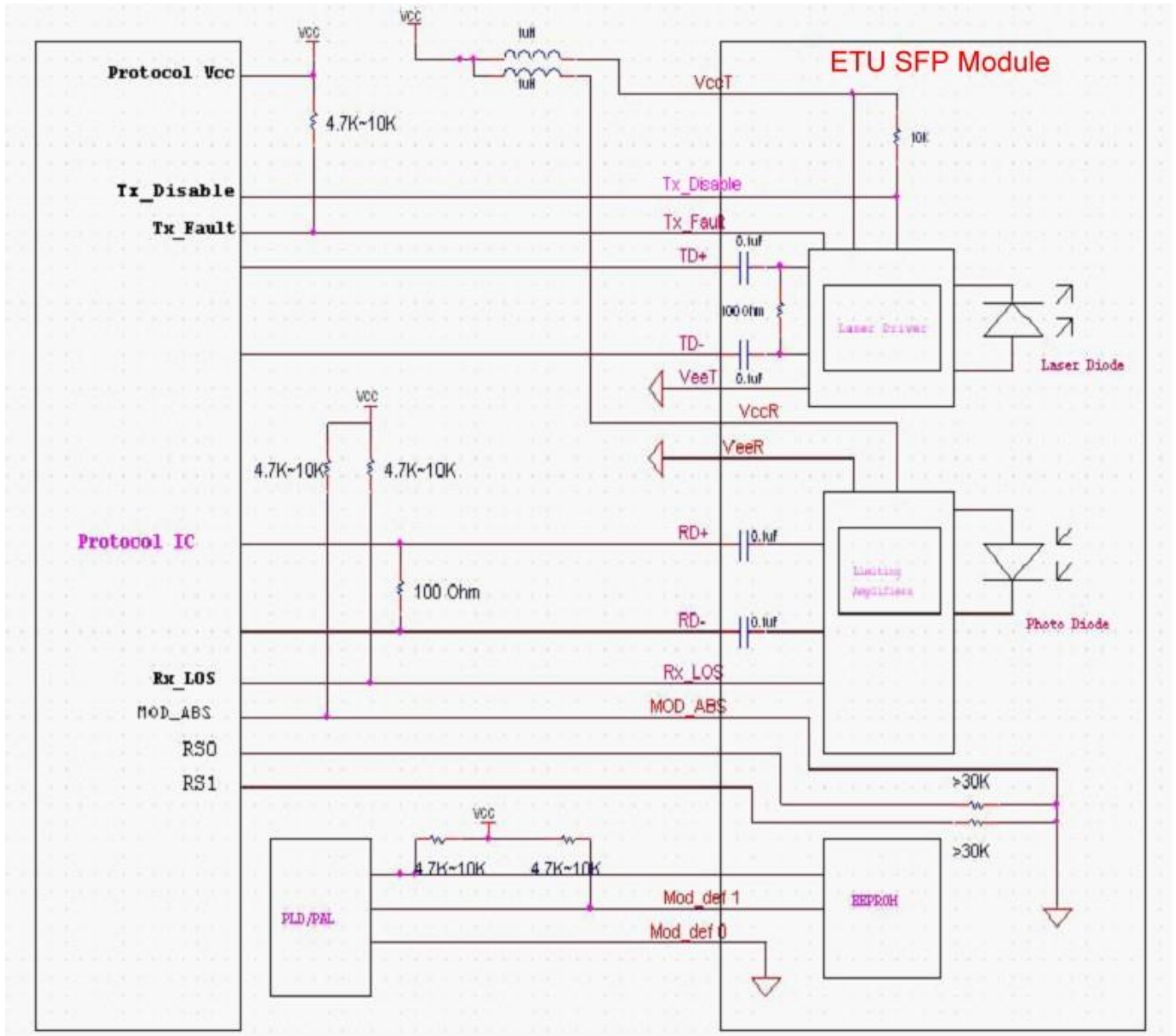

Outline Dimensions

Comply with SFF-8432 rev. 5.0, the improved Pluggable form factor specification.

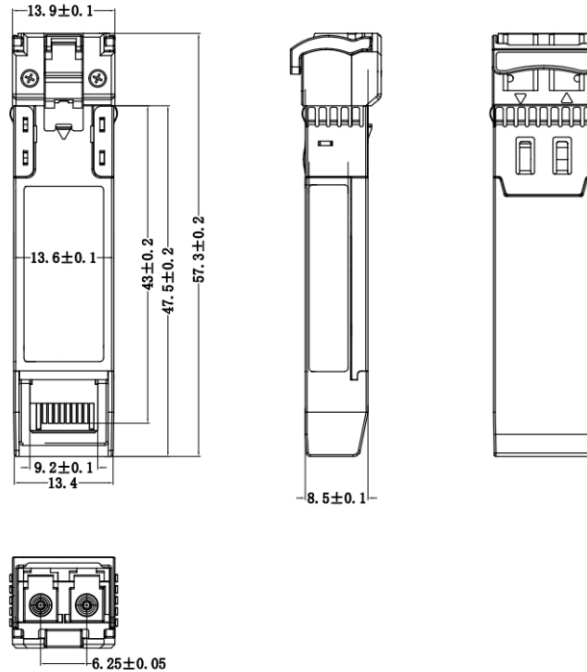

Regulatory Compliance

Feature	Reference	Performance
Electrostatic discharge (ESD)	IEC/EN 61000-4-2	Compatible with standards
Electromagnetic Interference (EMI)	FCC Part 15 Class B EN 55022 Class B (CISPR 22A)	Compatible with standards
Laser Eye Safety	FDA 21CFR 1040.10, 1040.11 IEC/EN 60825-1, 2	Class 1 laser product
Component Recognition	IEC/EN 60950, UL	Compatible with standards
ROHS	2002/95/EC	Compatible with standards
EMC	EN61000-3	Compatible with standards

Compatibility Test

In order to ensure the product compatibility, our products will be tested on the switch before shipment. Our modules can be compatible with many mainstream brand switches, such as Cisco, Juniper, Extreme, Brocade, IBM, H3C, HP, Huawei, D-Link, Mikrotik, ZTE, TP-Link...

Our test equipment: VOLKTEK MEN-4110, HP 2530-8G, CRS226-24G-25+RM, Catalyst 2960G Series, Catalyst 3850 XS 10G SFP+, Catalyst 3750-E Series, HUAWEI S5700 Series, H3C S3100V2 Series, Juniper-EX4200, etc.



HUAWEI S6720S



CISCO Catalyst 9500



DELL S5048F



H3C S3100V2



CISCO C3850



Aruba 2930F



Juniper EX 4200



HP J9264A



Quidway S5700

Product Production Process

Quality Assurance

Continuous introduction of new equipment,
produced by strict standards, strict quality inspection,
to guarantee the high quality, standard of each product.

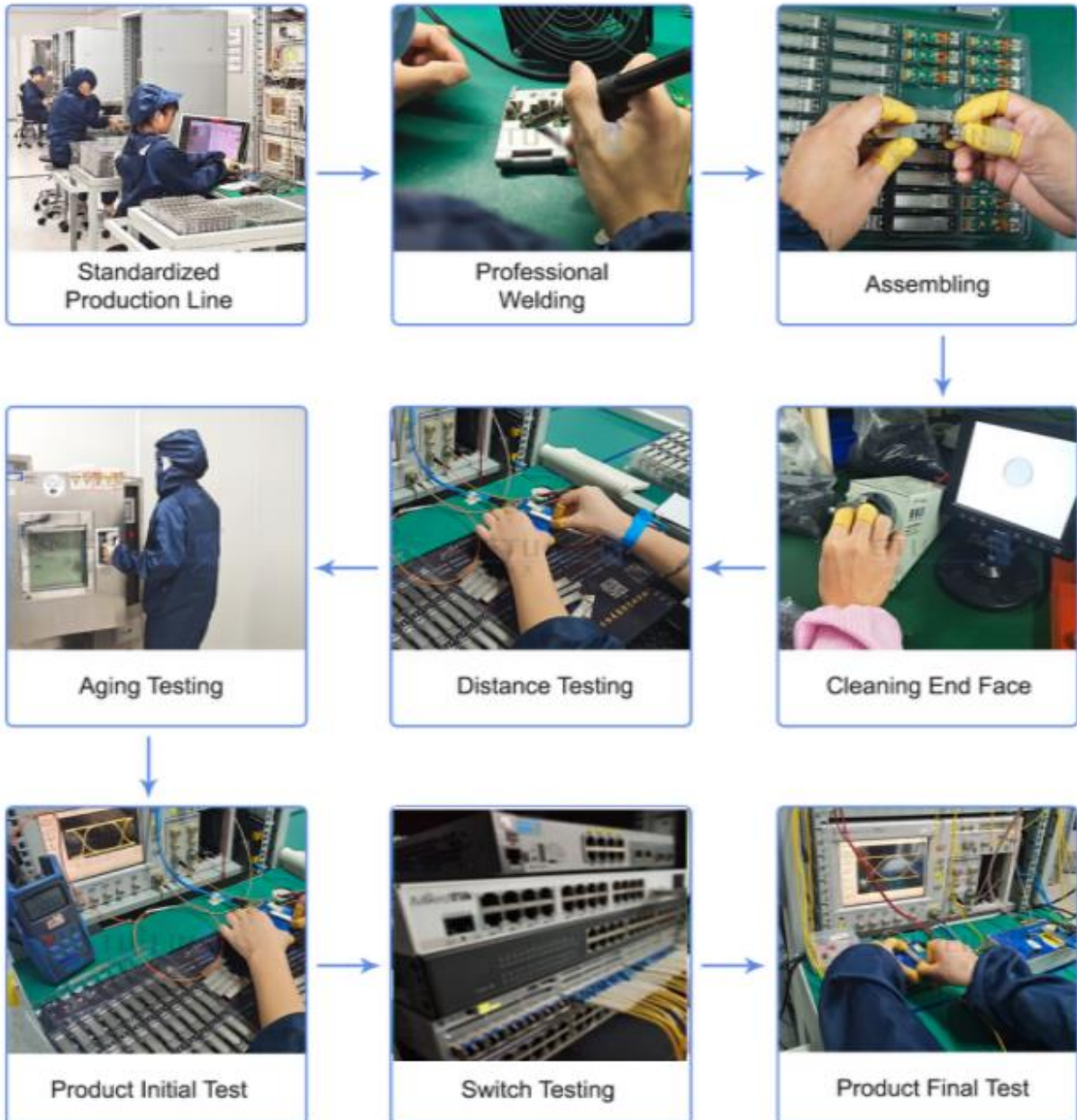

Packaging

ETU-Link provides two kinds of packaging, 10pcs/Tray and individual package.



Company: ETU-Link Technology Co., LTD

Production base: Right side of 3rd floor, No. 102 building, Longguan expressway, Dalang street, Longhua District, Shenzhen city, Guangdong Province, China 518109

R&D base: Floor 4, Building 4, Nanshan Yungu Phase LI, Taoyuan Community, Xili Street, Nanshan District, Shenzhen

Tel: +86-755 2328 4603

Addresses and phone number also have been listed at www.etulinktechnology.com.

Please e-mail us at sales@etulinktechnology.com or call us for assistance.